

Registers & Counters

BME208 – Logic Circuits

Yalçın İŞLER

islerya@yahoo.com

<http://me.islerya.com>

Registers

- Registers are clocked sequential circuits
- A register is a group of flip-flops
 - Each flip-flop capable of storing one bit of information
 - An n-bit register
 - consists of n flip-flops
 - capable of storing n bits of information
 - besides flip-flops, a register usually contains combinational logic to perform some simple tasks
 - In summary
 - flip-flops to hold information
 - combinational logic to control the state transition

Counters

- A counter is essentially a register that goes through a predetermined sequence of states
- “Counting sequence”

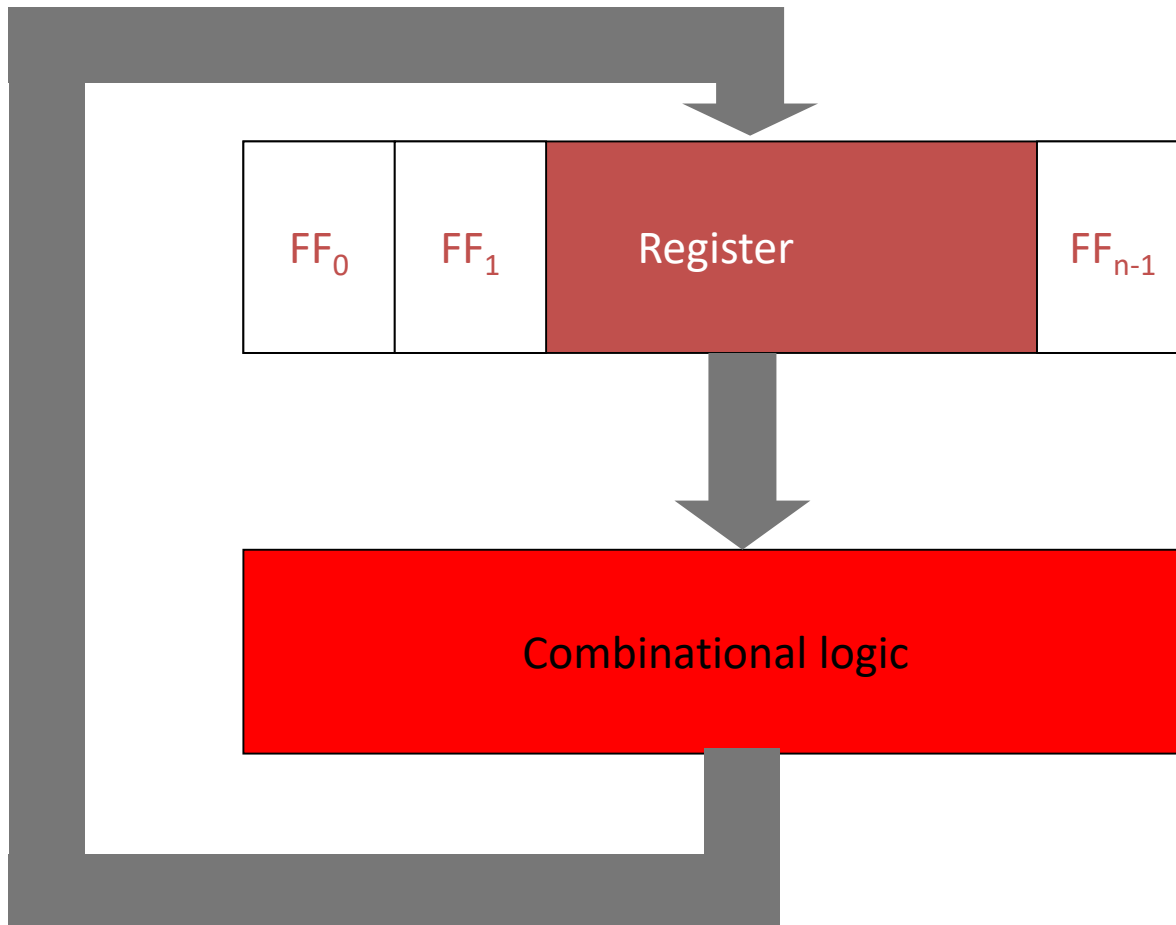

Uses of Registers and Counters

- Registers are useful for storing and manipulating information
 - internal registers in microprocessors to manipulate data
- Counters are extensively used in control logic
 - PC (program counter) in microprocessors

4-bit Register

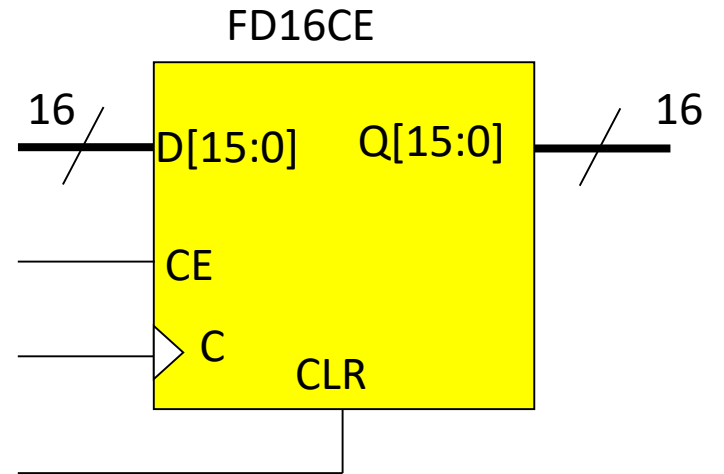
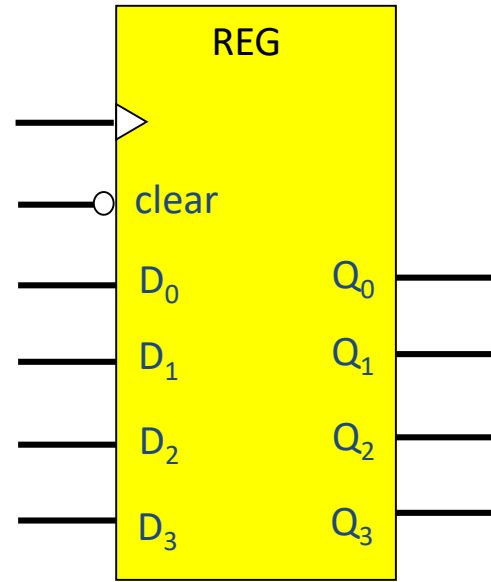
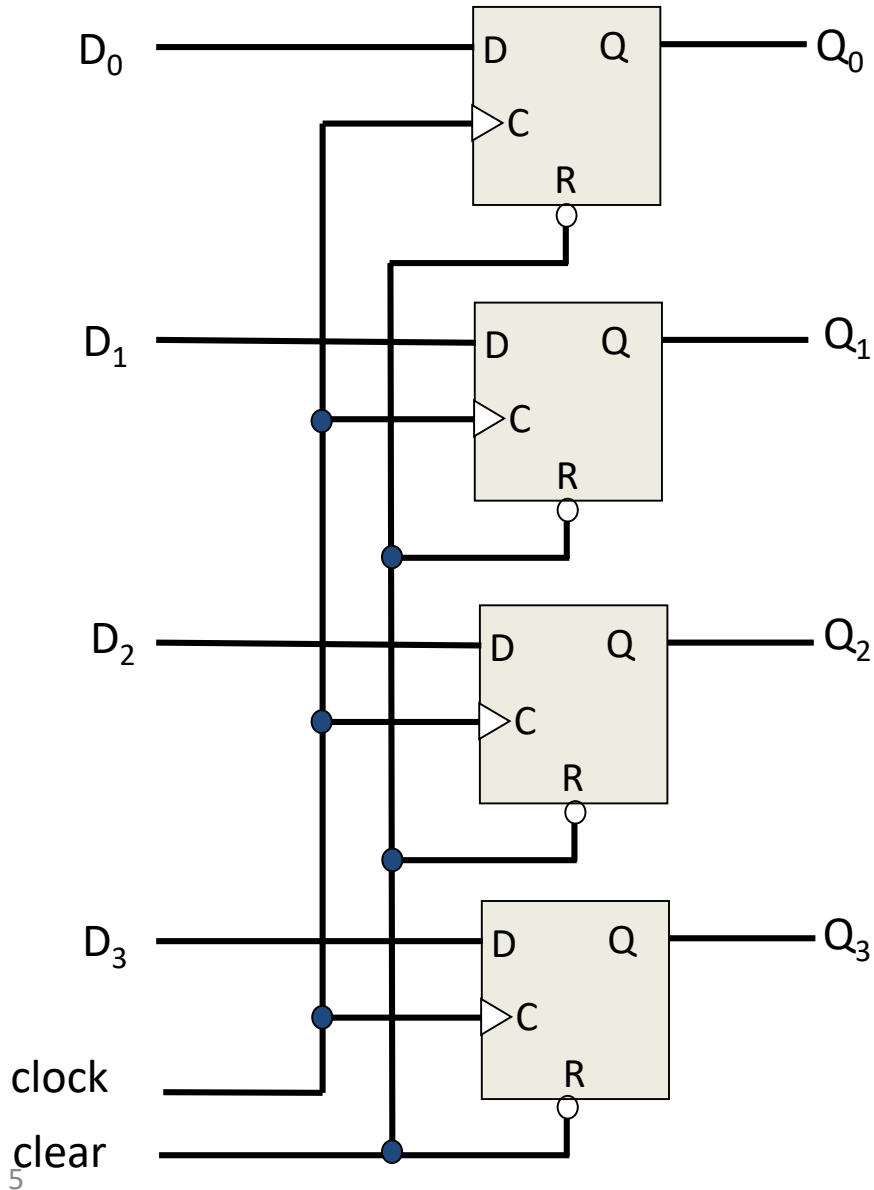

Verilog Code of FD16CE

```
always @ (posedge C or posedge CLR)
  begin
    if (CLR)
      Q <= 4'b0000;
    else
      begin
        if (CE)
          Q <= D;
      end
    end
  end
```

Register with Parallel Load

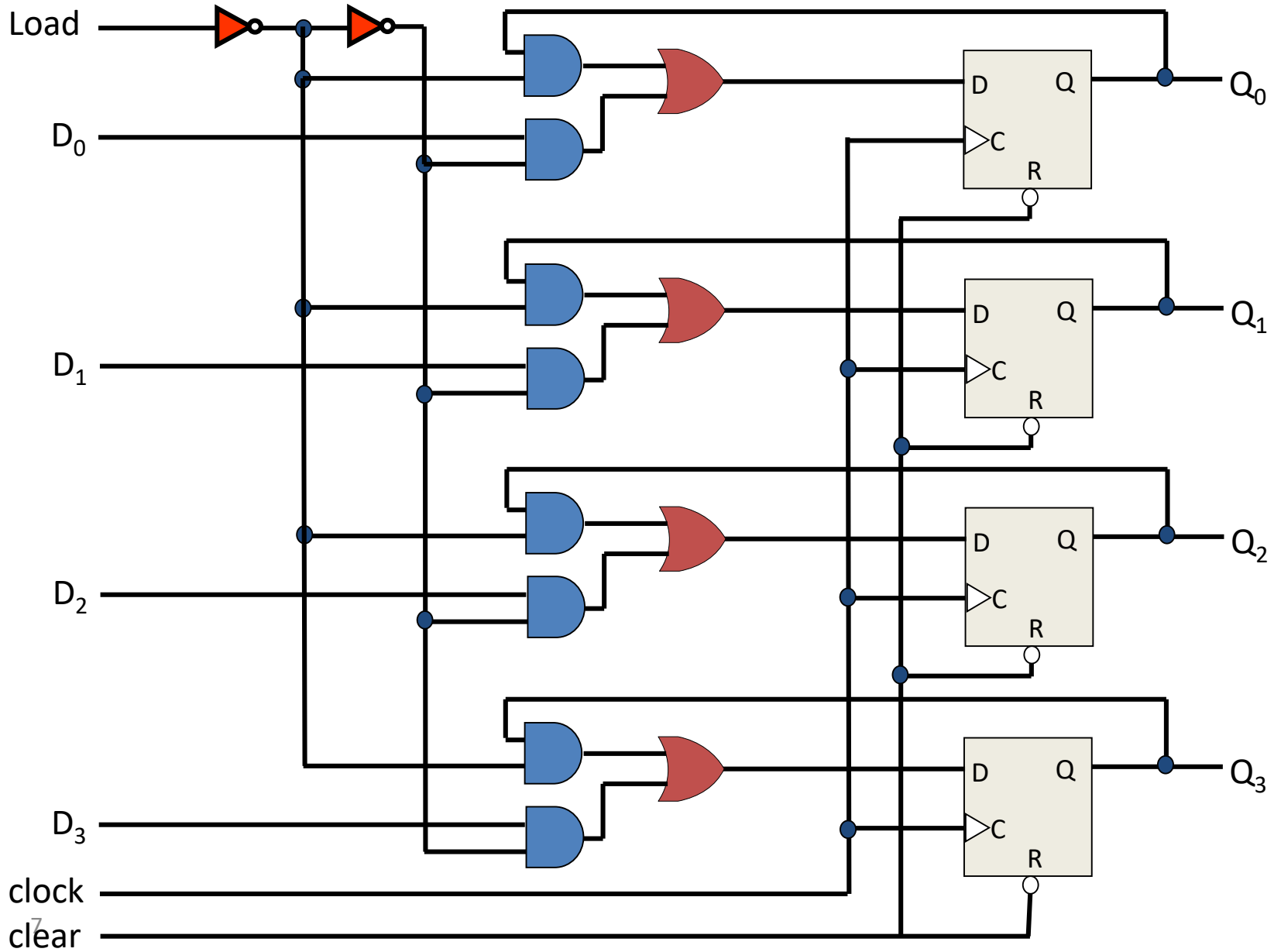

Register Transfer 1/2

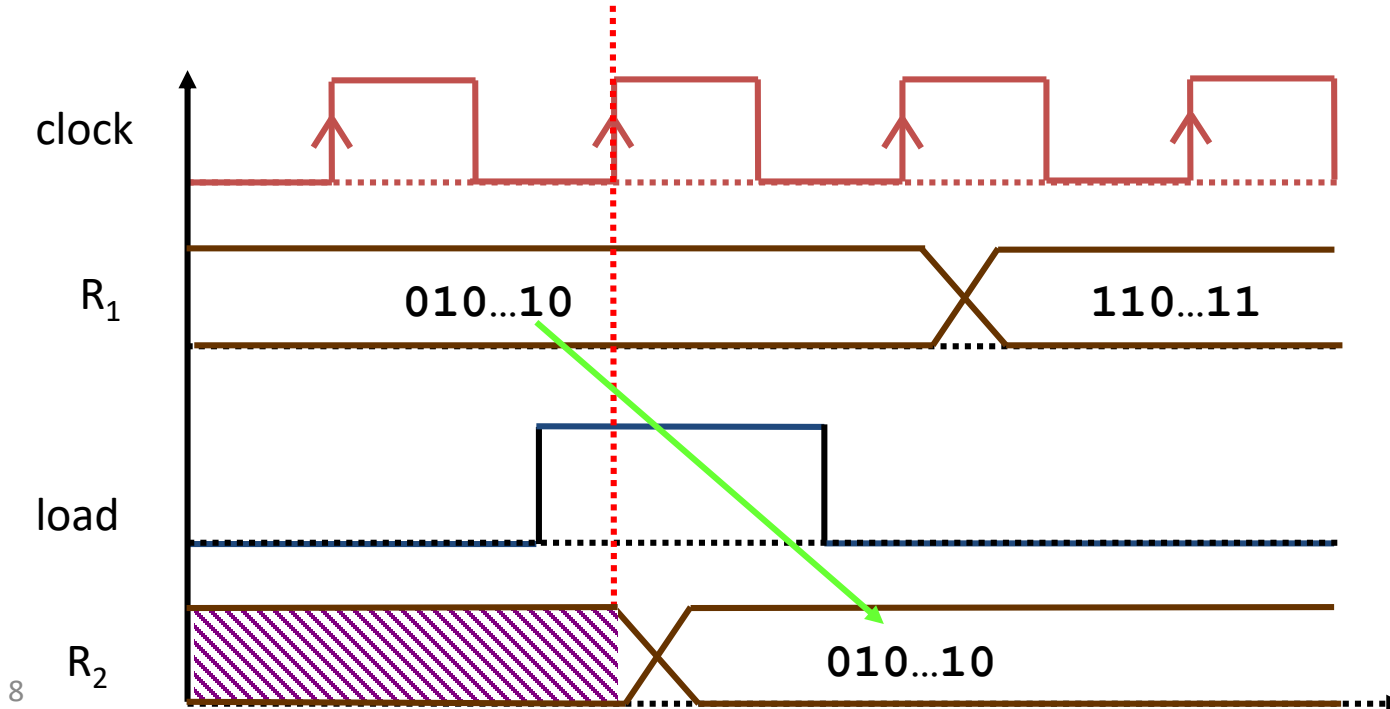
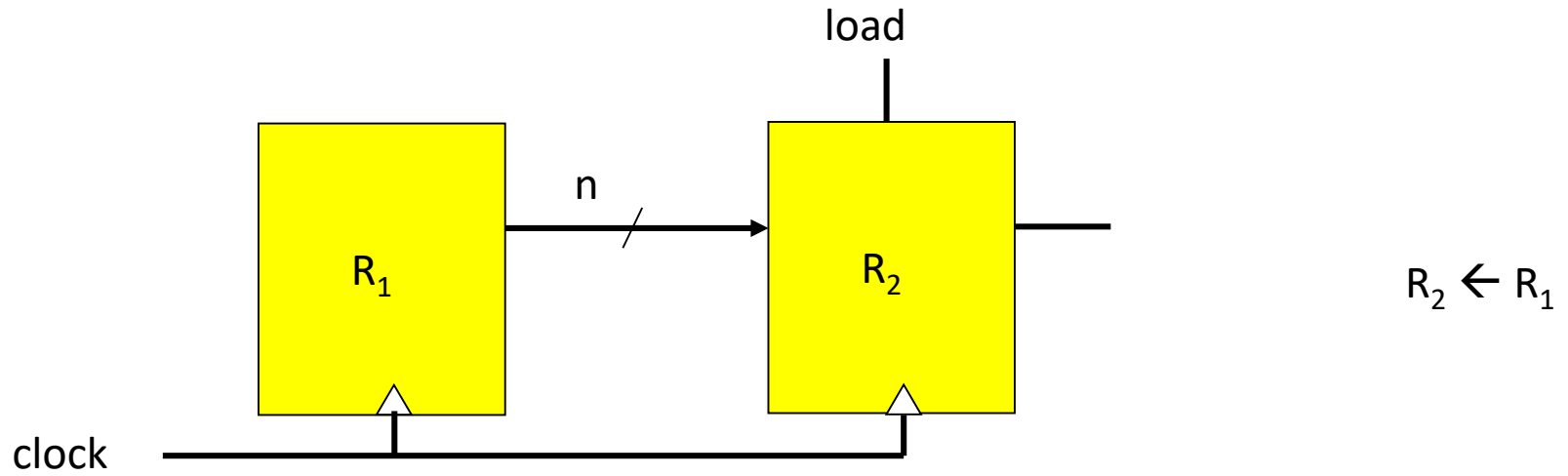

Register Transfer 2/2

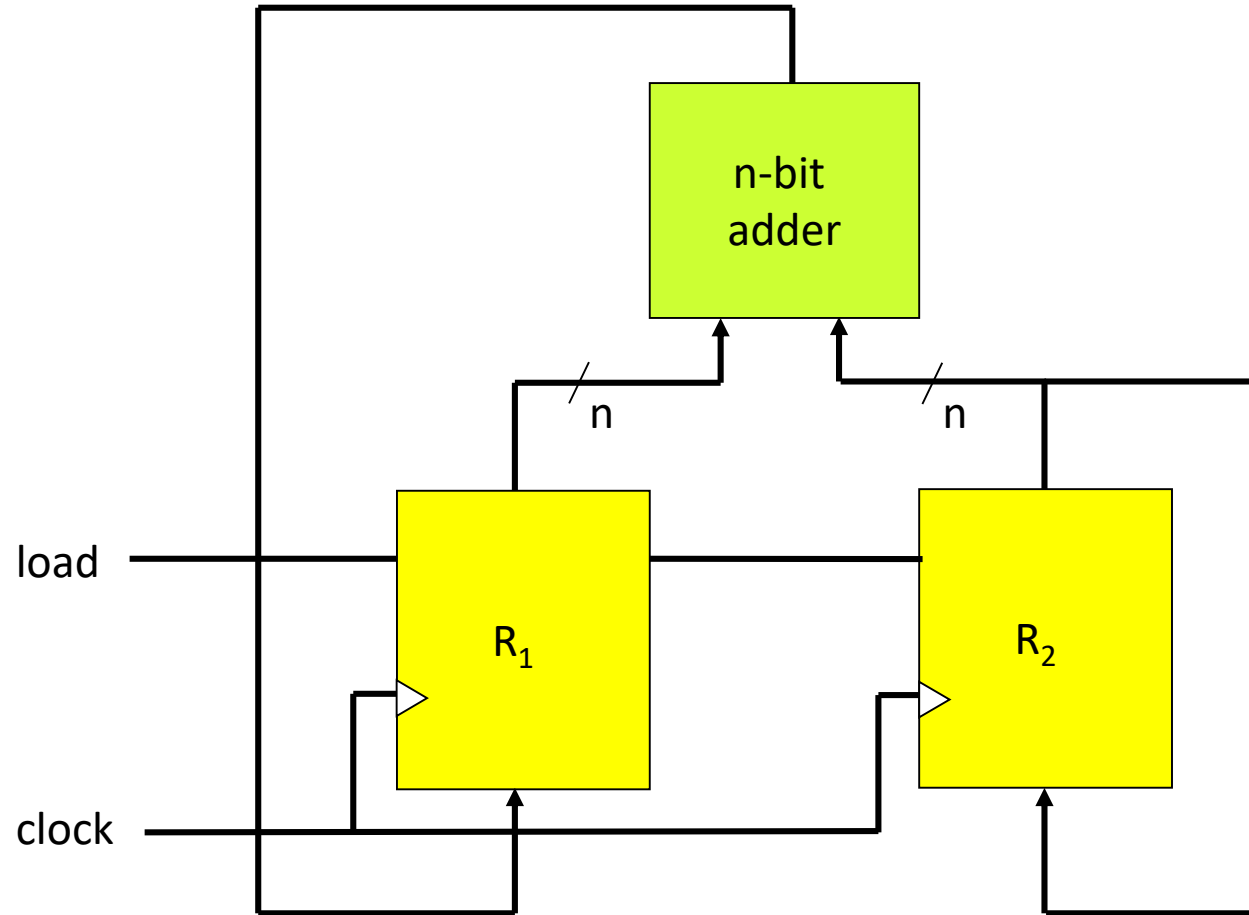

$$R_1 \leftarrow R_1 + R_2$$

Shift Registers

- A register capable of shifting its content in one or both directions
 - Flip-flops in cascade

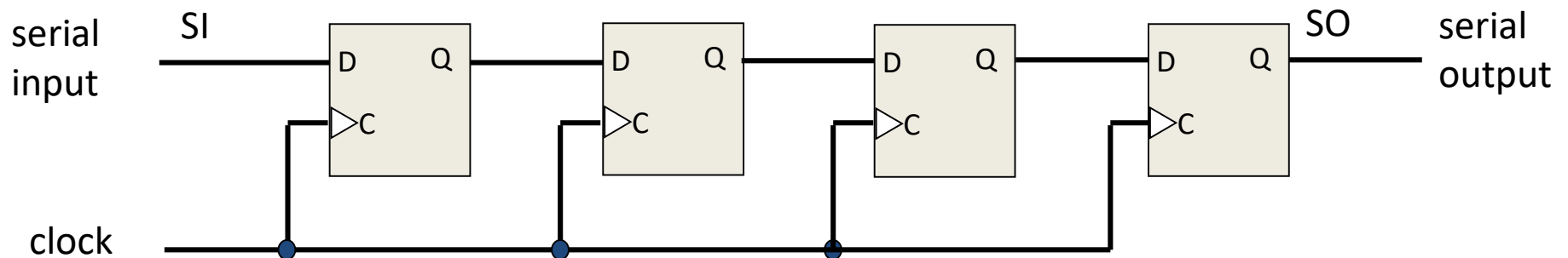

- The current of n-bit shift register state can be transferred in n clock cycles

Serial Mode

- A digital system is said to operate in serial mode when information is transferred and manipulated one bit a time.

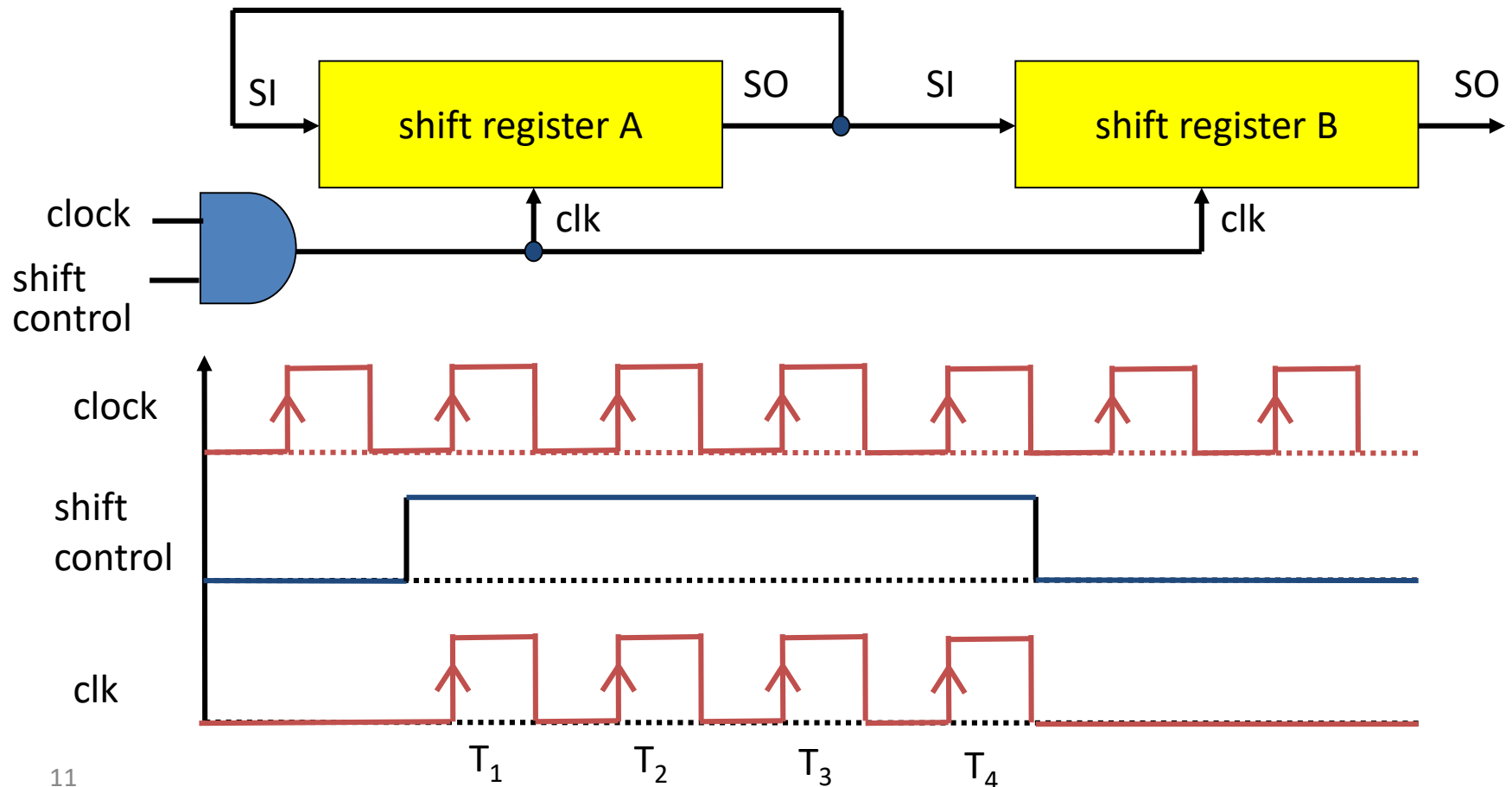

$B \leftarrow A$

Serial Transfer

- Suppose we have two 4-bit shift registers

Timing pulse	Shift register A				Shift register B			
initial value	1	0	1	1	0	0	1	0
After T_1								
After T_2								
After T_3								
After T_4	1	0	1	1	1	0	1	1

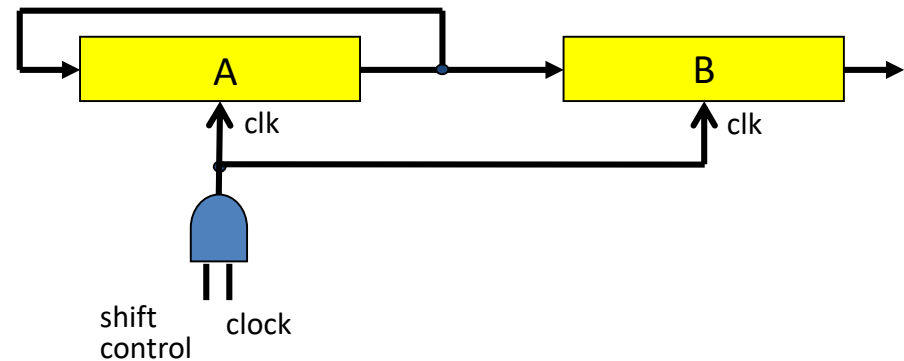
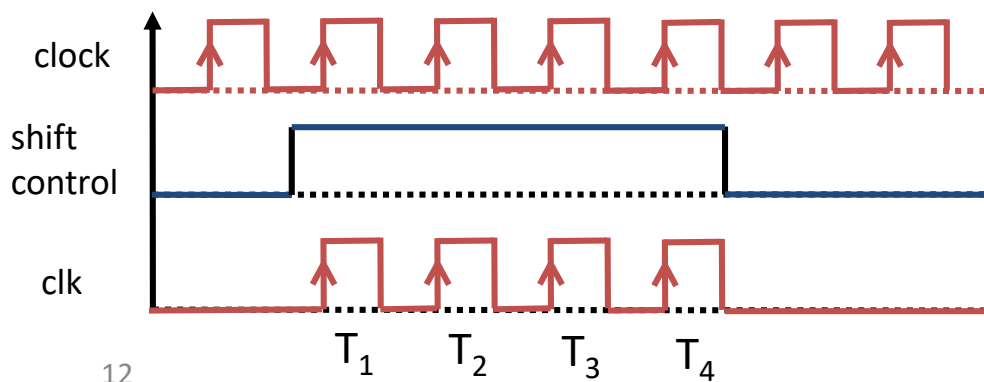

Serial Addition

- In digital computers, operations are usually executed in parallel, since it is faster
- Serial mode is sometimes preferred since it requires less equipment

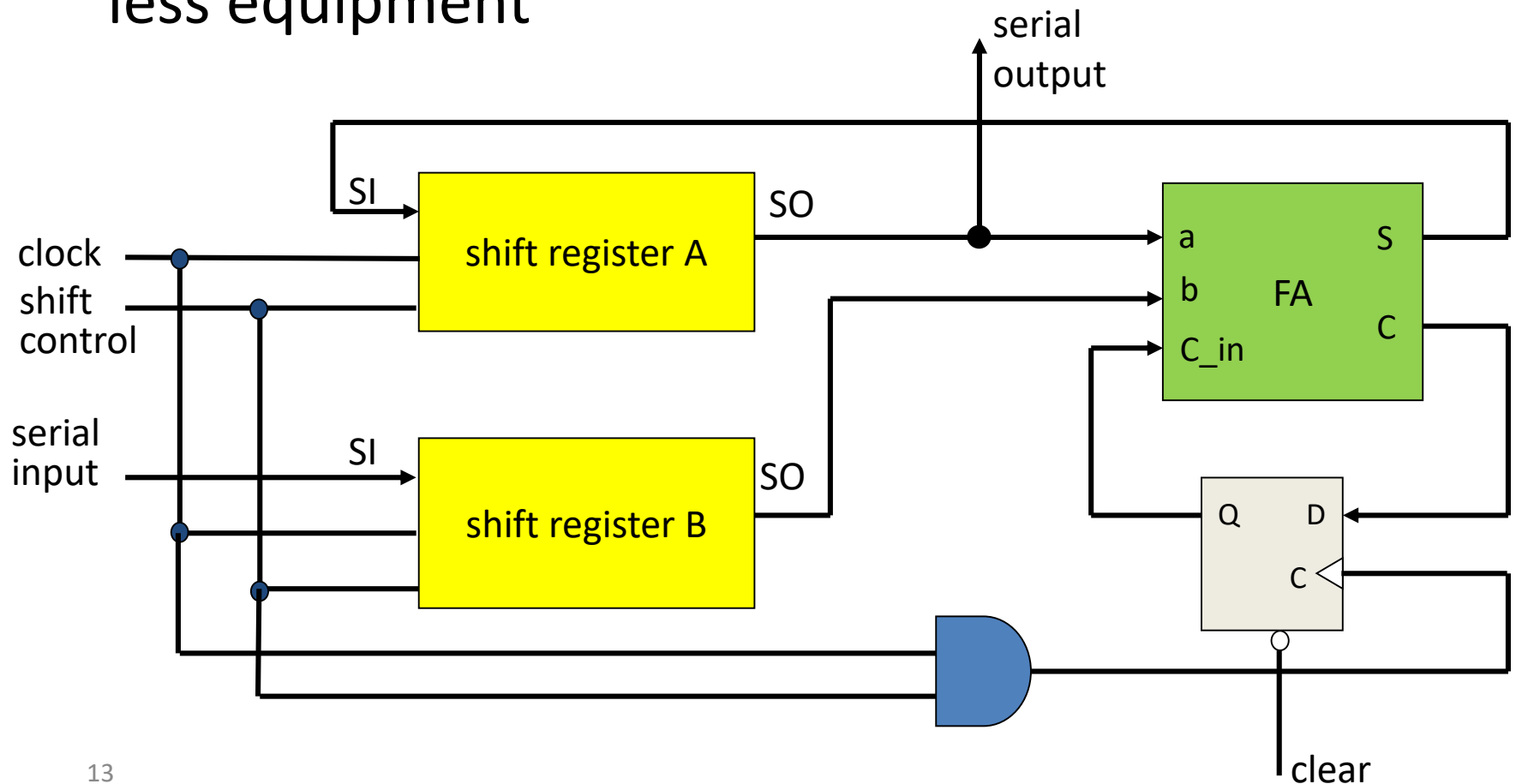

Example: Serial Addition

- A and B are 2-bit shift registers

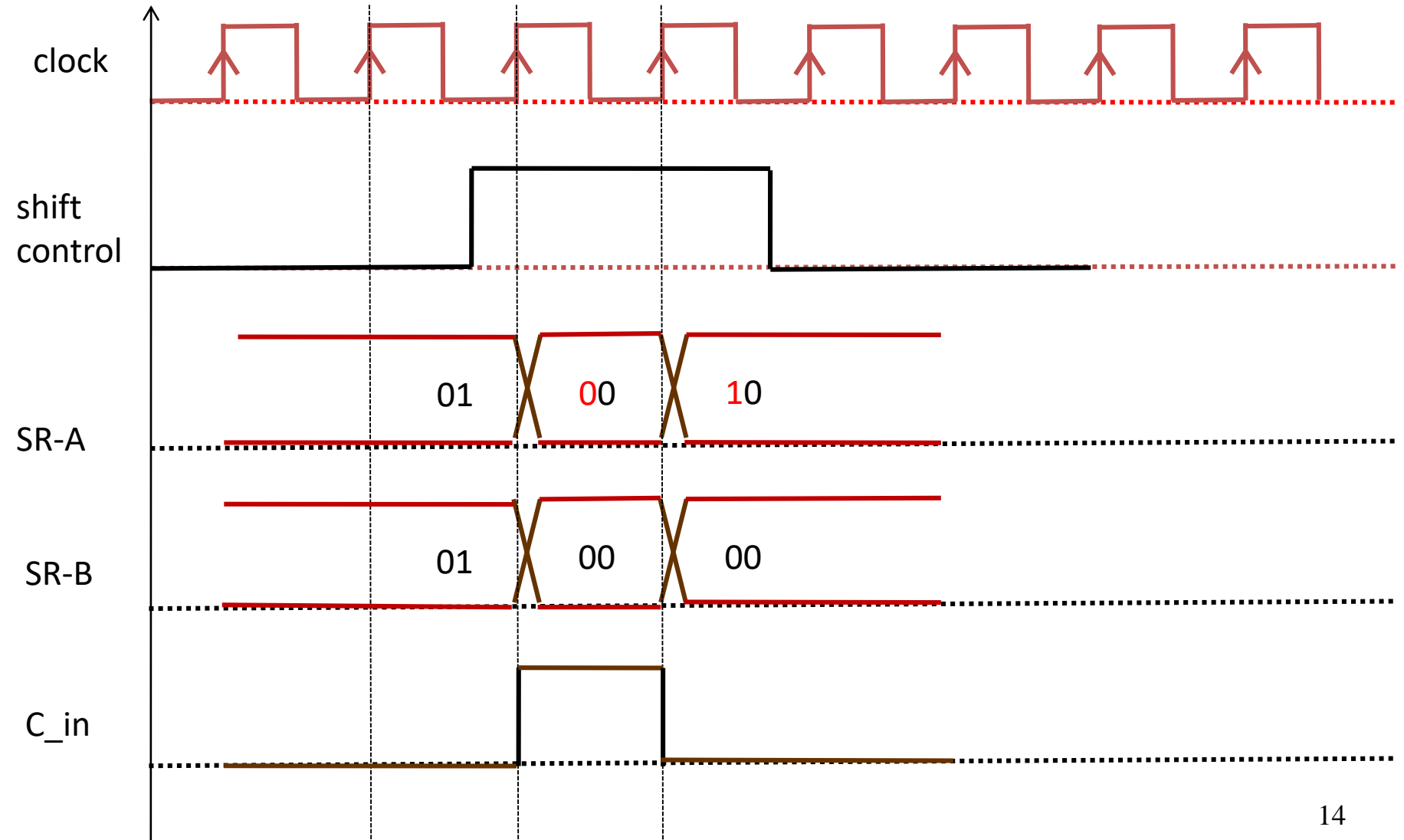

Universal Shift Register

- Capabilities:
 1. A “clear” control to set the register to 0.
 2. A “clock” input
 3. A “shift-right” control
 4. A “shift-left” control
 5. n input lines & a “parallel-load” control
 6. n parallel output lines

Verilog Code – v1

```
// Behavioral description of a 4-bit universal shift register
// Fig. 6.7 and Table 6.3
module Shift_Register_4_beh (           // V2001, 2005
output reg [3: 0] A_par,              // Register output
input [3: 0] I_par,                  // Parallel input
input s1, s0,                        // Select inputs
MSB_in, LSB_in,                       // Serial inputs
CLK, Clear_b                          // Clock and Clear
always @ ( posedge CLK, negedge Clear_b) // V2001, 2005
    if (Clear_b == 0) A_par <= 4'b0000;
    else
        case ({s1, s0})
            2'b00: A_par <= A_par;           // No change
            2'b01: A_par <= {MSB_in, A_par[3: 1]}; // Shift right
            2'b10: A_par <= {A_par[2: 0], LSB_in}; // Shift left
            2'b11: A_par <= I_par;          // Parallel load of input
        endcase
endmodule
```

Verilog Code – v2

```
// Behavioral description of a 4-bit universal shift register
// Fig. 6.7 and Table 6.3
module Shift_Register_4_beh (           // V2001, 2005
output reg [3: 0] A_par,             // Register output
input [3: 0] I_par,                 // Parallel input
input s1, s0,                       // Select inputs
MSB_in, LSB_in,                      // Serial inputs
CLK, Clear_b                         // Clock and Clear
always @ ( posedge CLK, negedge Clear_b) // V2001, 2005
    if (Clear_b == 0) A_par <= 4'b0000;
    else
        case ({s1, s0})
            // 2'b00: A_par <= A_par; // No change
            2'b01: A_par <= {MSB_in, A_par [3: 1]}; // Shift right
            2'b10: A_par <= {A_par [2: 0], LSB_in}; // Shift left
            2'b11: A_par <= I_par; // Parallel load of input
        endcase
endmodule
```

Universal Shift Register

Mode Control		
s_1	s_0	Register operation
0	0	No change
0	1	Shift right
1	0	Shift left
1	1	Parallel load

Counters

- registers that go through a prescribed sequence of states upon the application of input pulses
 - input pulses are usually clock pulses
- Example: n-bit binary counter
 - count in binary from 0 to 2^n-1
- Classification
 1. Synchronous counters
 - flip-flops receive the same common clock as *the* pulse
 2. Ripple counters
 - flip-flop output transition serves as *the* pulse to trigger other flip-flops

Binary Ripple Counter

3-bit binary ripple counter

0	0	0	0
1	0	0	1
2	0	1	0
3	0	1	1
4	1	0	0
5	1	0	1
6	1	1	0
7	1	1	1
0	0	0	0

- Idea:
 - to connect the output of one flip-flop to the C input of the next high-order flip-flop
- We need “complementing” flip-flops
 - We can use T flip-flops to obtain complementing flip-flops or
 - JK flip-flops with its inputs are tied together or
 - D flip-flops with complement output connected to the D input.

4-bit Binary Ripple Counter

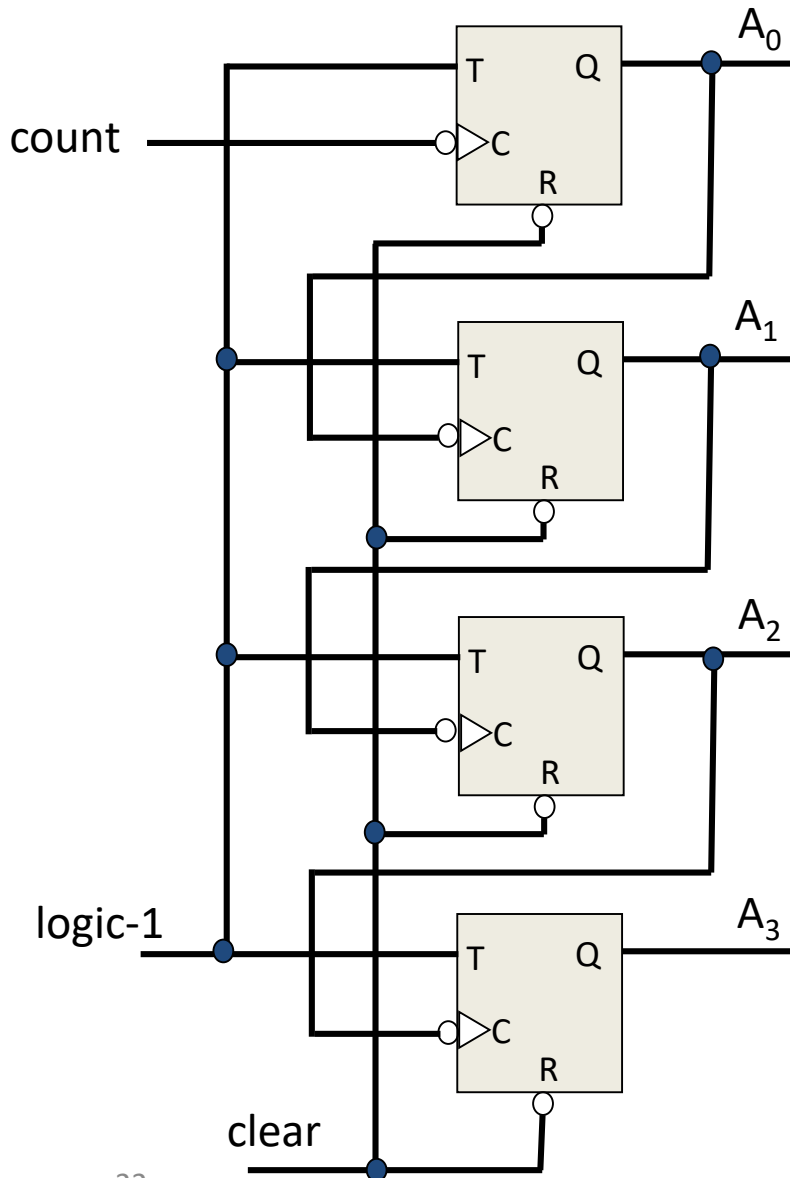

0	0	0	0	0
1	0	0	0	1
2	0	0	1	0
3	0	0	1	1
4	0	1	0	0
5	0	1	0	1
6	0	1	1	0
7	0	1	1	1
8	1	0	0	0
9	1	0	0	1
10	1	0	1	0
11	1	0	1	1
12	1	1	0	0
13	1	1	0	1
14	1	1	1	0
15	1	1	1	1
0	0	0	0	0

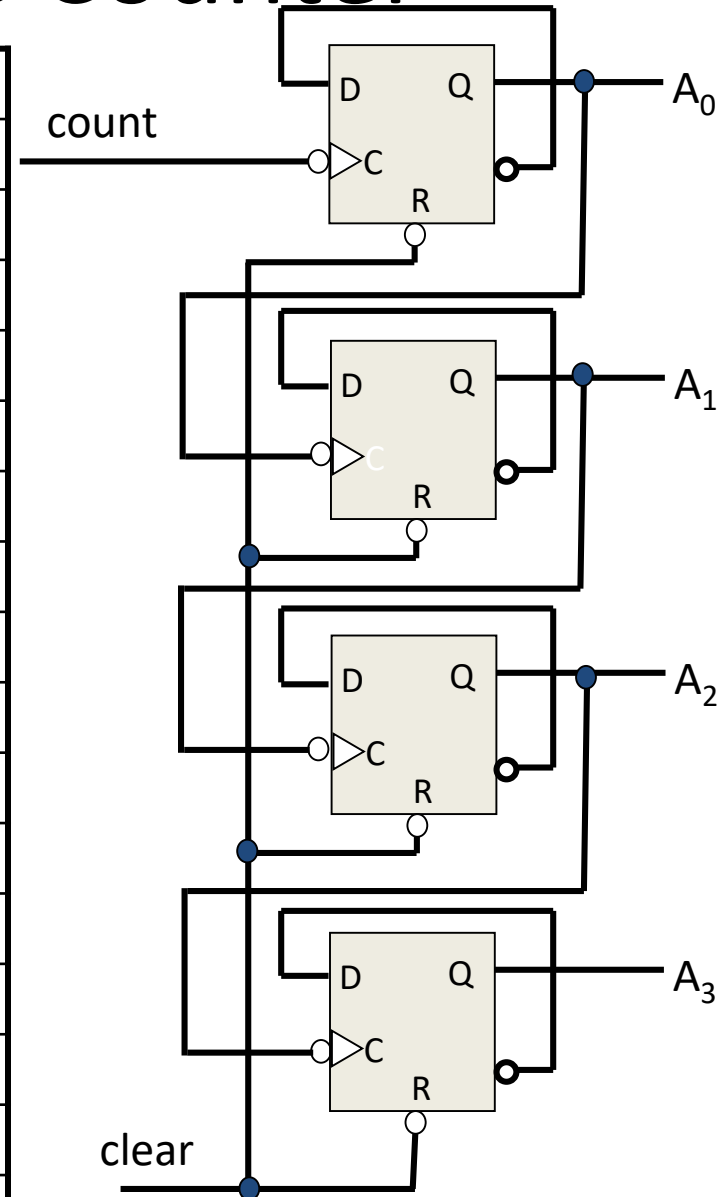

4-bit Binary Ripple Counter

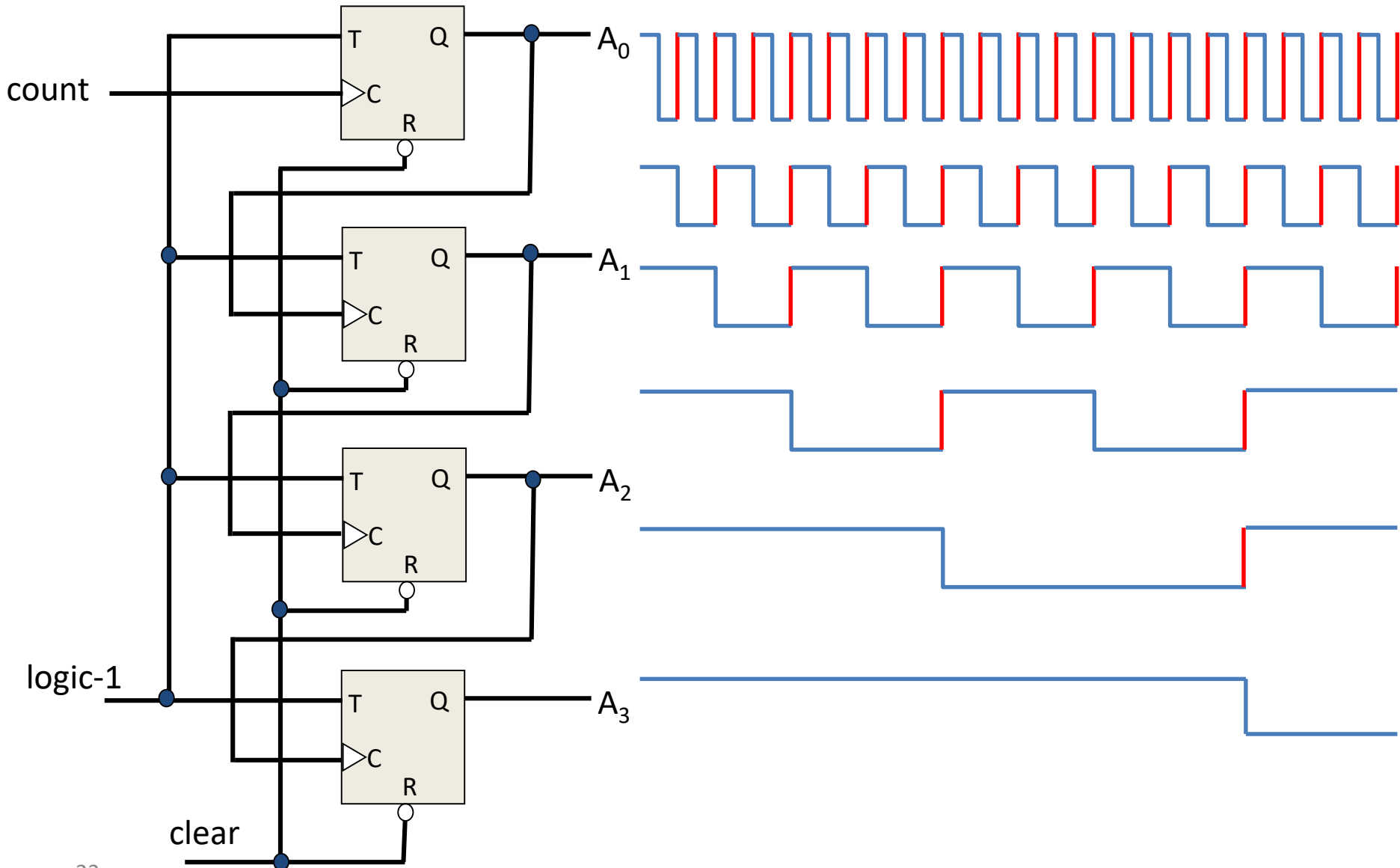

Synchronous Counters

- There is a common clock
 - that triggers all flip-flops simultaneously
 - If $T = 0$ or $J = K = 0$ the flip-flop does not change state.
 - If $T = 1$ or $J = K = 1$ the flip-flop does change state.
- Design procedure is so simple
 - no need for going through sequential logic design process
 - A_0 is always complemented
 - A_1 is complemented when $A_0 = 1$
 - A_2 is complemented when $A_0 = 1$ and $A_1 = 1$
 - so on

0	0 0 0
1	0 0 1
2	0 1 0
3	0 1 1
4	1 0 0
5	1 0 1
6	1 1 0
7	1 1 1
0	0 0 0

Timing of Synchronous Counters

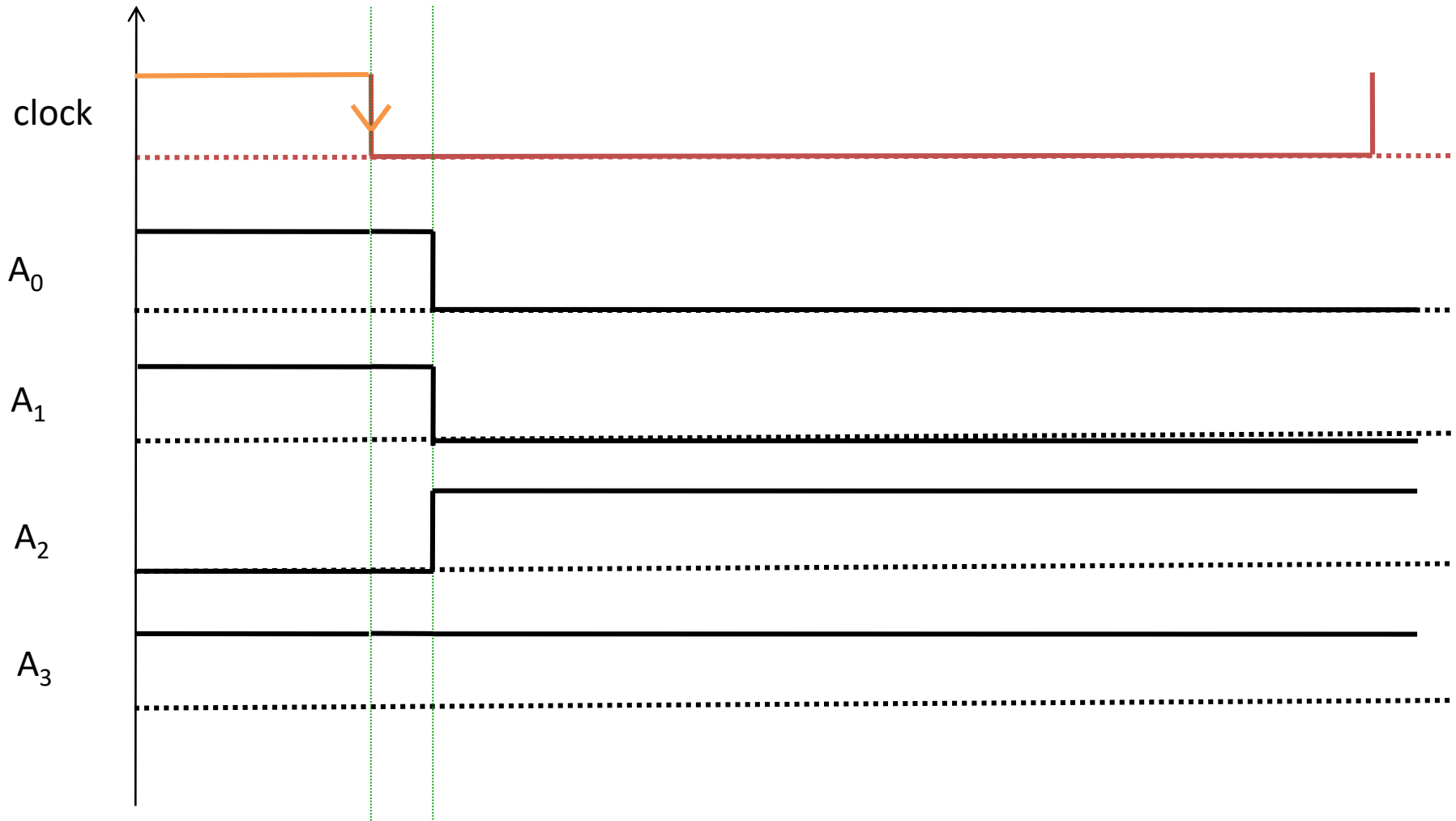

Timing of Ripple Counters

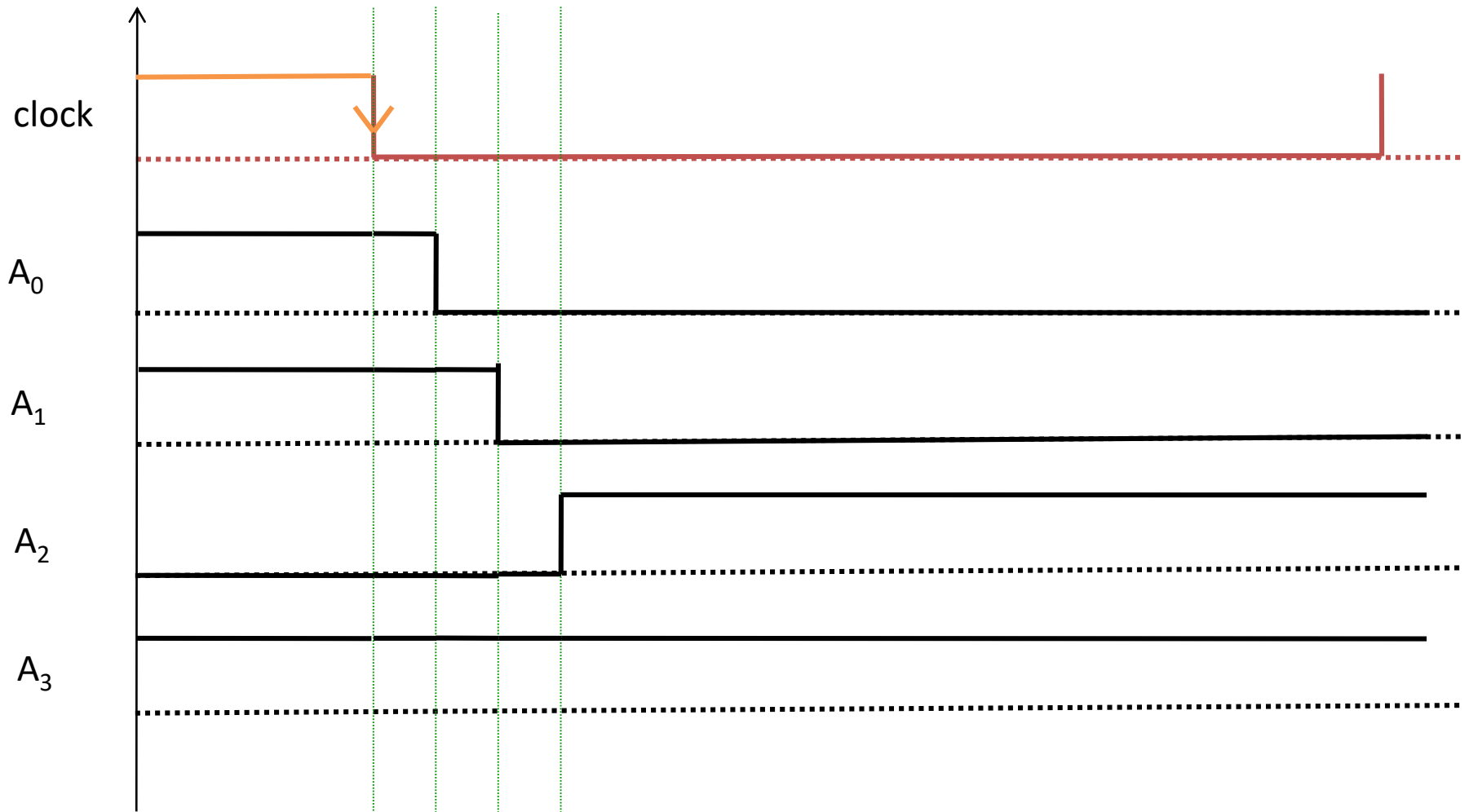

Up-Down Binary Counter

- When counting downward
 - the least significant bit is always complemented (with each clock pulse)
 - A bit in any other position is complemented if all lower significant bits are equal to 0.
 - For example: **0 1 0 0**
 - Next state:
 - For example: **1 1 0 0**
 - Next state:

0	0 0 0
7	1 1 1
6	1 1 0
5	1 0 1
4	1 0 0
3	0 1 1
2	0 1 0
1	0 0 1
0	0 0 0

Up-Down Binary Counter

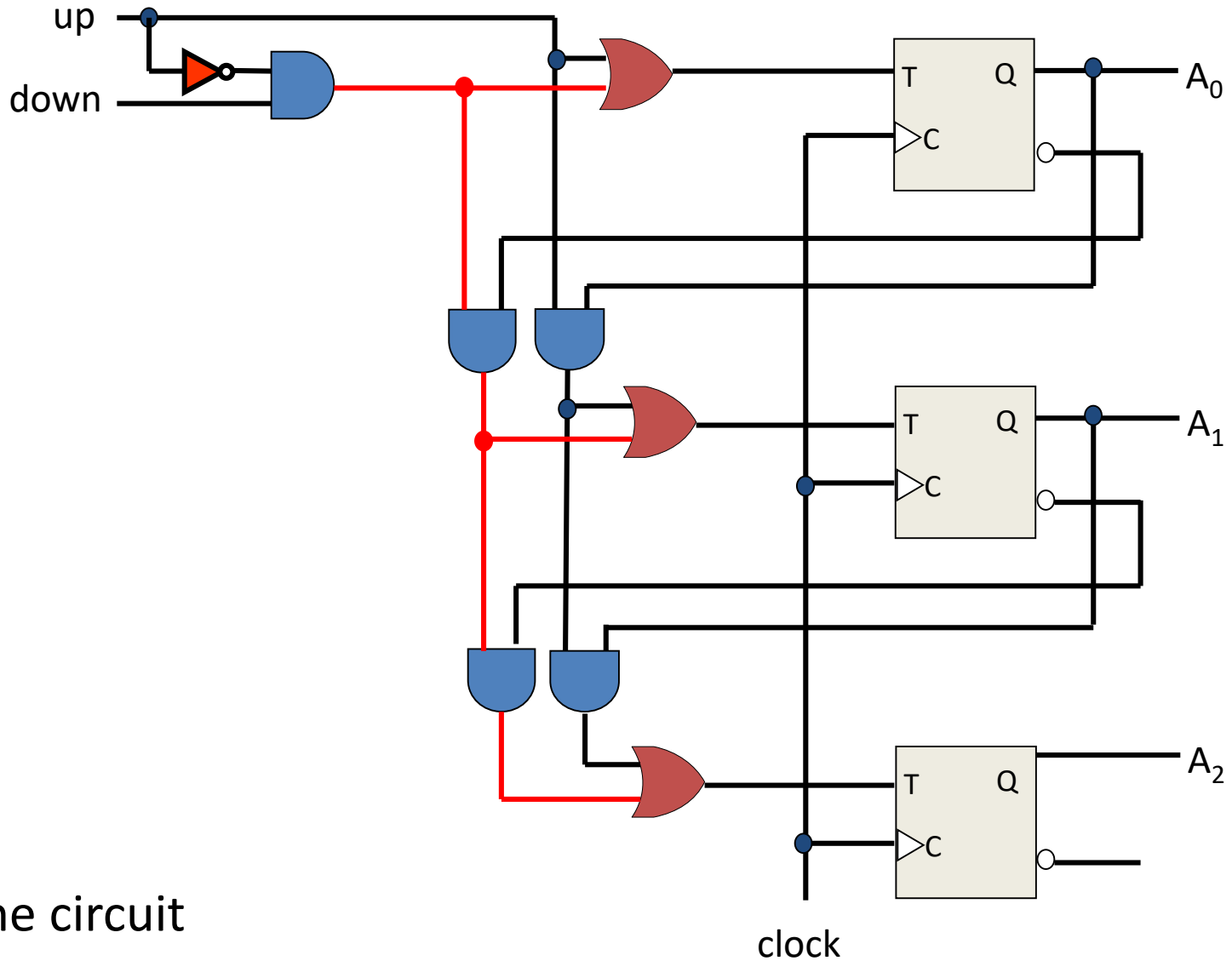

- The circuit

Binary Counter with Parallel Load

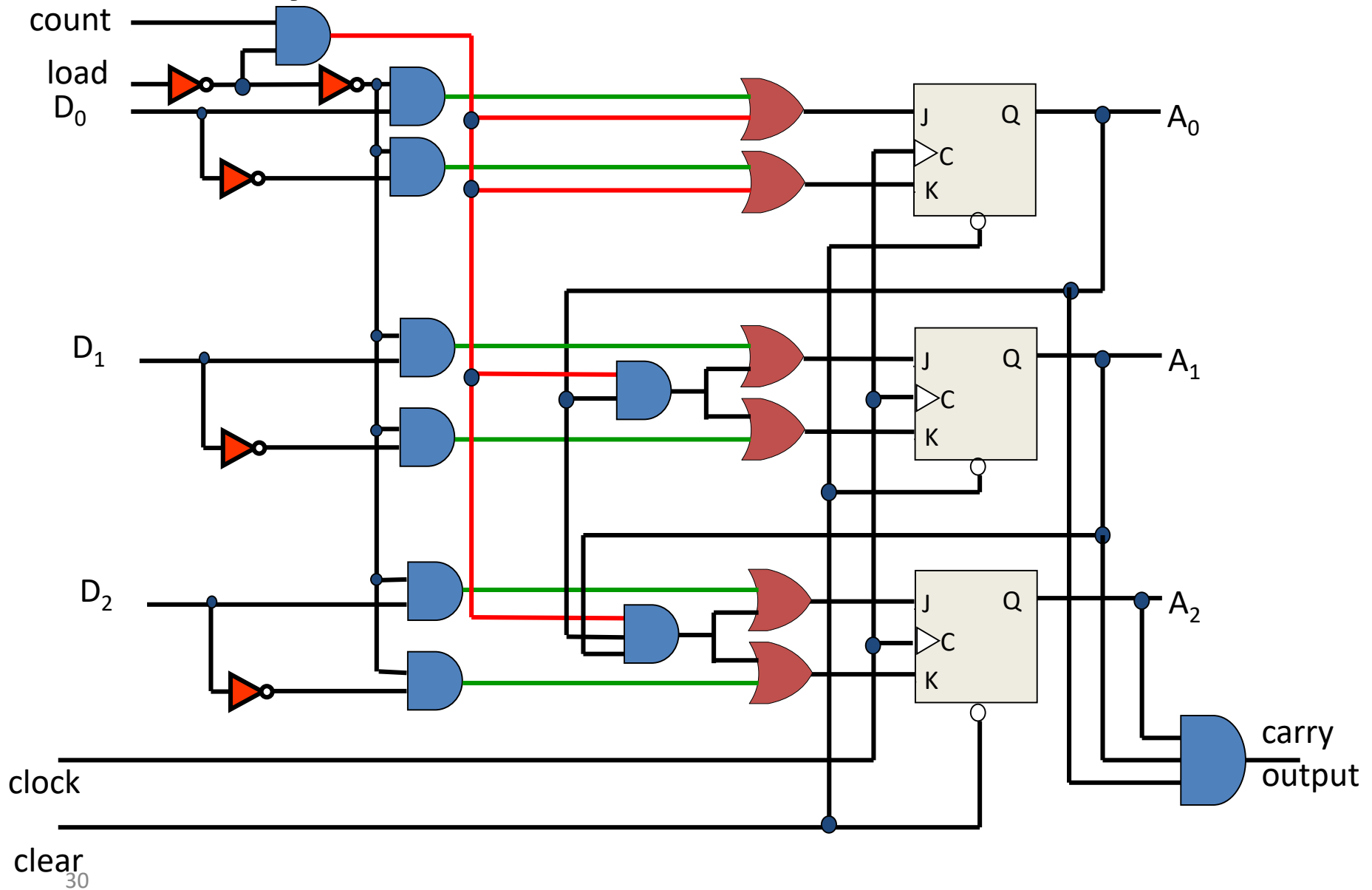

Binary Counter with Parallel Load

Function Table

clear	clock	load	Count	Function
0	X	X	X	clear to 0
1	↑	1	X	load inputs
1	↑	0	1	count up
1	↑	0	0	no change

Other Counters

- Ring Counter

- A ring counter is a circular shift register with only one flip-flop being set at any particular time, all others are cleared.

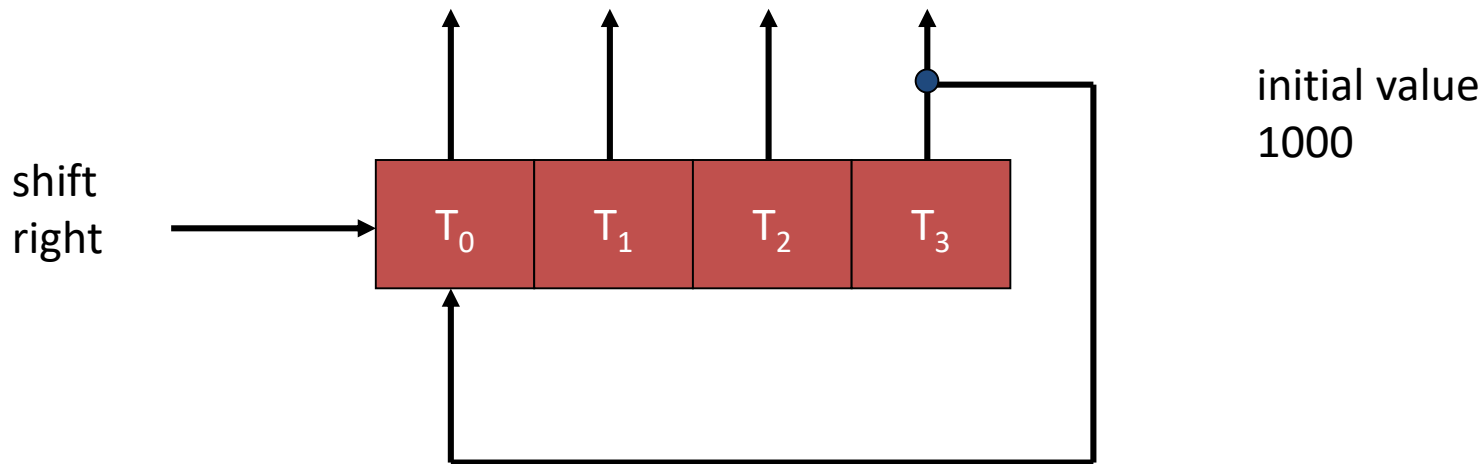

- Usage

- Timing signals control the sequence of operations in a digital system

Ring Counter

- Sequence of timing signals

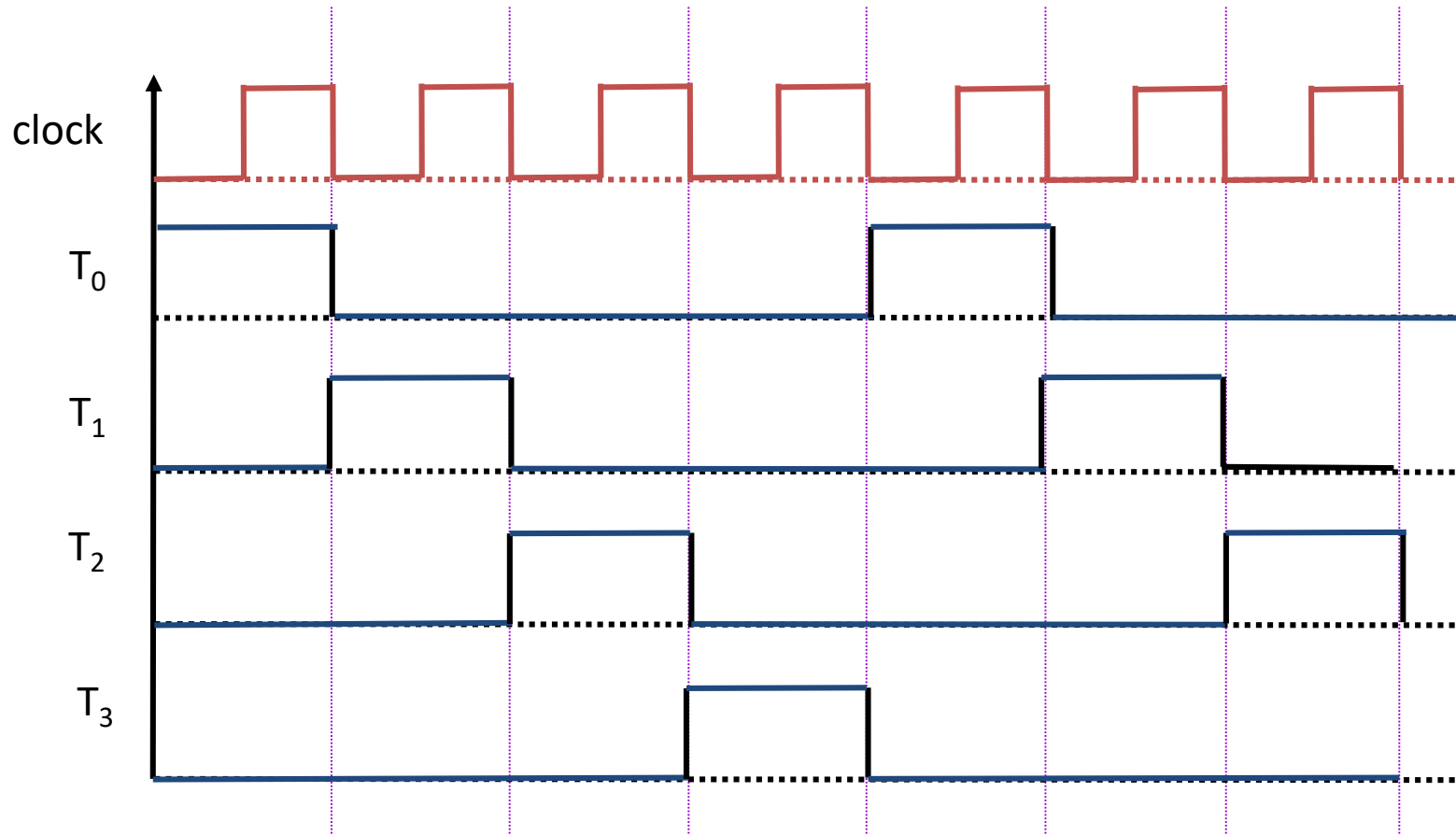

Ring Counter

- To generate 2^n timing signals,
 - we need a shift register with ? flip-flops
- or, we can construct the ring counter with a binary counter and a decoder

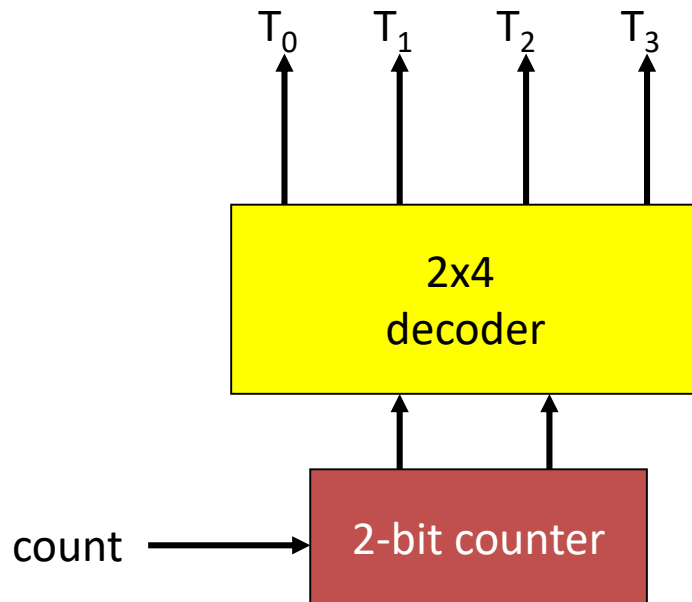

Cost:

- 2 flip-flops
- 2-to-4 line decoder

Cost in general case:

- n flip-flops
- n-to- 2^n line decoder
 - 2^n n-input AND gates
 - n NOT gates

Johnson Counter

- A k-bit ring counter can generate k distinguishable states
- The number of states can be doubled if the shift register is connected as a switch-tail ring counter

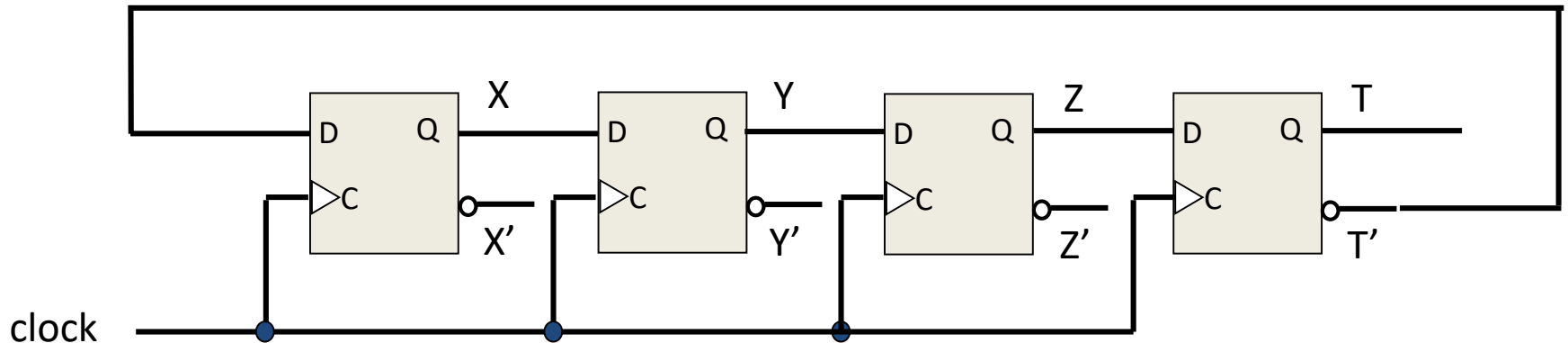

Johnson Counter

- Count sequence and required decoding

sequence number	Flip-flop outputs				Output
	X	Y	Z	T	
1	0	0	0	0	$S_0 = X'T'$
2	1	0	0	0	$S_1 = XY'$
3	1	1	0	0	$S_2 = YZ'$
4	1	1	1	0	$S_3 = ZT'$
5	1	1	1	1	$S_4 = XT$
6	0	1	1	1	$S_5 = X'Y$
7	0	0	1	1	$S_6 = Y'Z$
8	0	0	0	1	$S_7 = Z'T$

Johnson Counter

- Decoding circuit

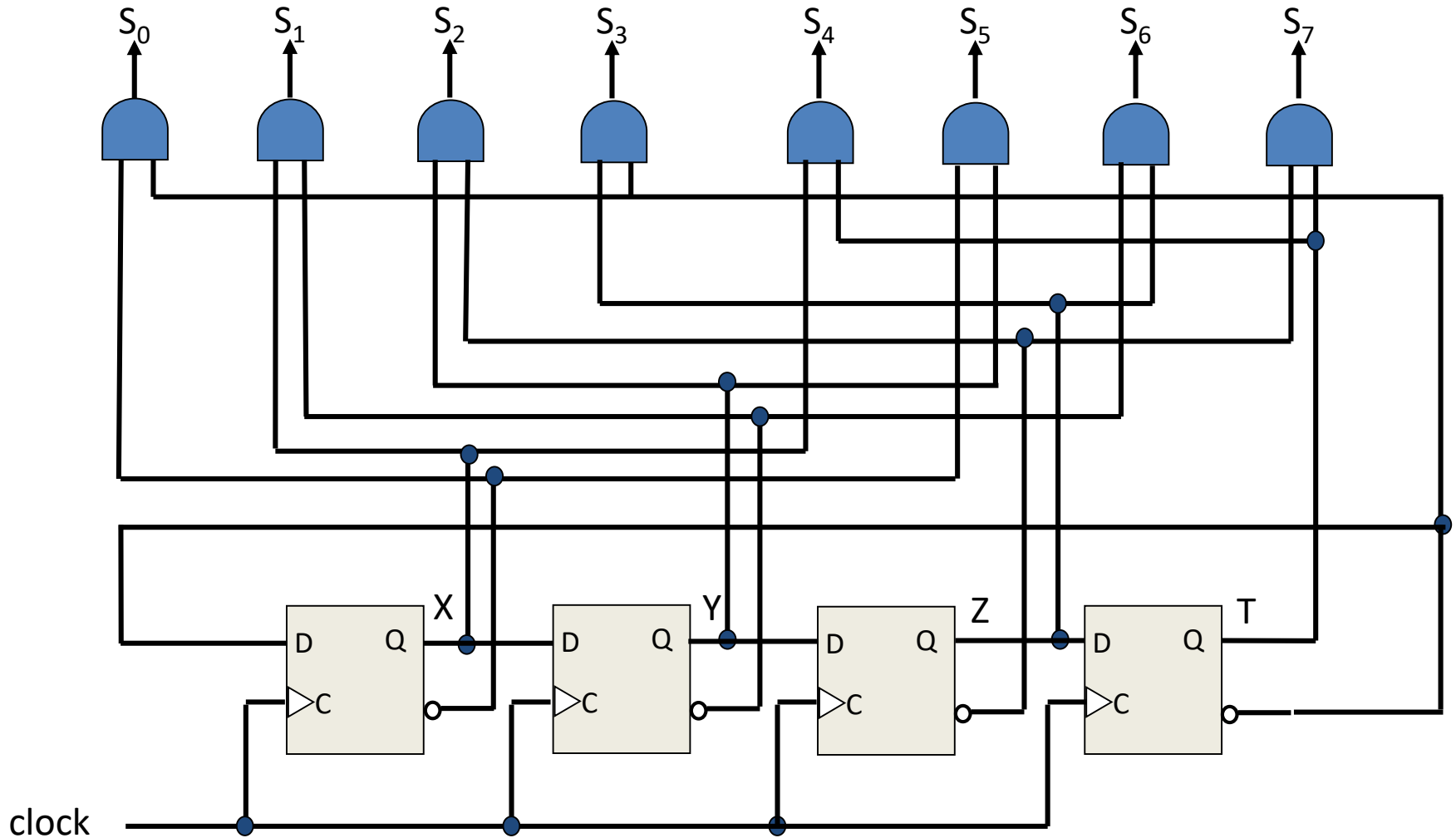

Unused States in Counters

- 4-bit Johnson counter

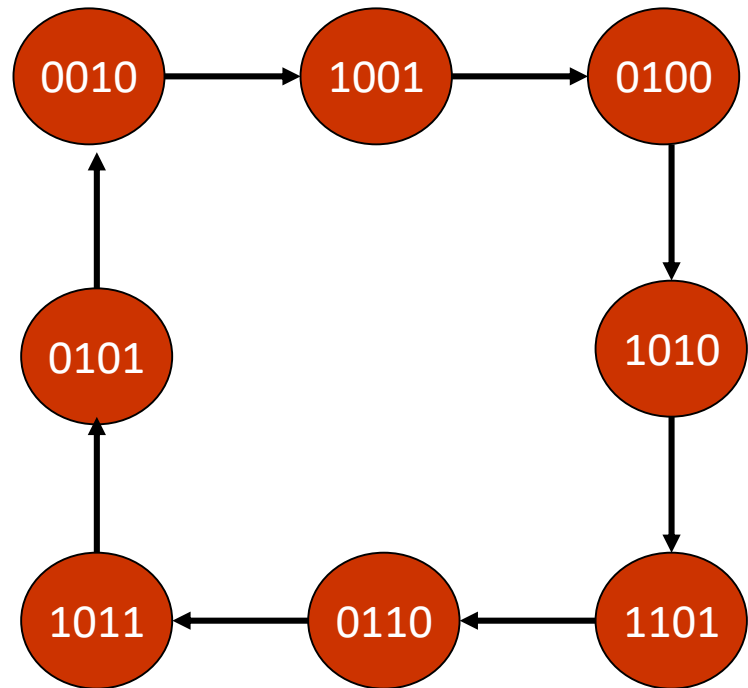
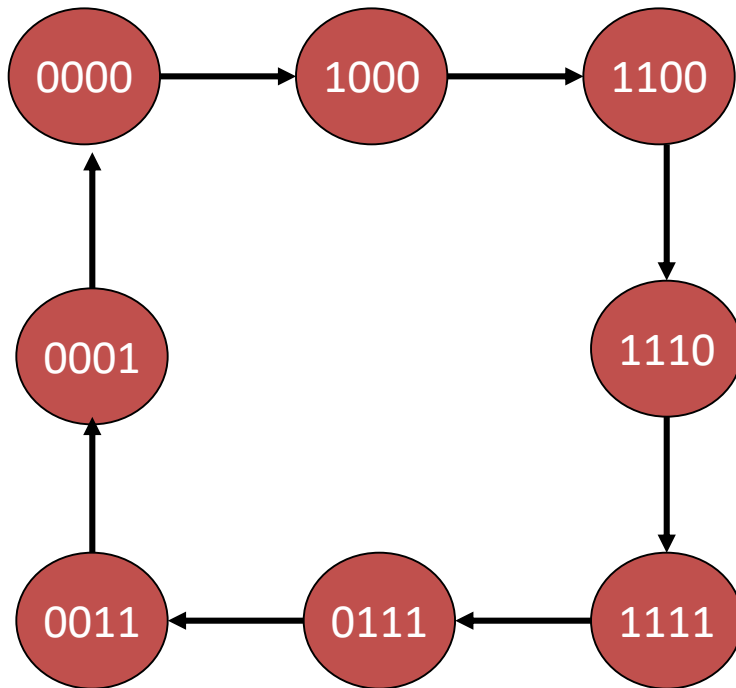

Johnson Counter

Present State				Next State			
X	Y	Z	T	X	Y	Z	T
0	0	0	0	1	0	0	0
1	0	0	0	1	1	0	0
1	1	0	0	1	1	1	0
1	1	1	0	1	1	1	1
1	1	1	1	0	1	1	1
0	1	1	1	0	0	1	1
0	0	1	1	0	0	0	1
0	0	0	1	0	0	0	0
0	0	1	0	1	0	0	1
1	0	0	1	0	0	0	0
0	1	0	0	1	0	1	0
1	0	1	0	1	1	0	1
1	1	0	1	0	1	1	0
0	1	1	0	1	0	1	1
1	0	1	1	0	1	0	1
0	1	0	1	0	0	1	0

K-Maps

		ZT			
		00	01	11	10
XY	00	1			1
	01	1			1
	11	1			1
	10	1			1

$$X(t+1) = T'$$

		ZT			
		00	01	11	10
XY	00				
	01				
	11	1	1	1	1
	10	1	0	1	1

$$Y(t+1) = XY + XZ + XT'$$

		ZT			
		00	01	11	10
XY	00				
	01	1	1	1	1
	11	1	1	1	1
	10				

$$Z(t+1) = Y$$

		ZT			
		00	01	11	10
XY	00			1	1
	01			1	1
	11			1	1
	10			1	1

$$T(t+1) = Z$$

Unused States in Counters

- Remedy $X(t+1) = T'$ $Y(t+1) = XY + XZ + XT'$
 $Z(t+1) = Y$ $T(t+1) = Z$

